

Motor Moteur		kW
n=		min ⁻¹
x=		mm
φy=		mm
z=		mm
e=		mm
p=		mm

max. Flüssigkeitsspiegel
max. liquid level
niveau maxi. du liquide

min. Flüssigkeitsspiegel beim Einschalten
min. liquid level when starting the pump
niveau mini. du liquide à la mise en marche

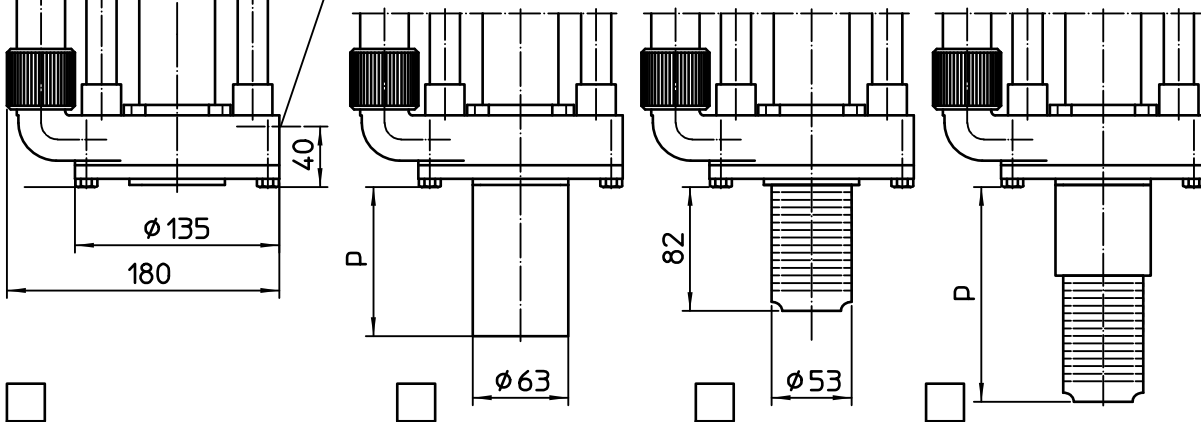

Einbaumaße:
Mounting dimensions:
Dimensions de montage:

